

SMART FUEL FILTER

FUEL FILTER - WATER SEPARATOR - INTEGRAL WATER PROBE



NEW! SFH-N2K-SS system with NMEA 2000 Certified plug & play interface and connector.

The Signal Filters™ SMART Fuel Filter System alerts you of water in your fuel system. Signal Filters™ is the only "SMART" spin on fuel filter/water separator with an internal water probe. A water in fuel alert can provide early warning of trouble. The Signal Filters™ system is available with standard mount gauge or dash indicator light. The 10 micron, high efficiency, water separating, spin on filter is available in three standard lengths 4", 6" and 8".

The Signal Filters™ SMART Fuel Filter System comes with a 316 stainless steel head with mounting bracket and (4) 3/8" NPT ports. Signal Filters™ System is approved for gasoline or diesel fuels.

The Signal Filters™ System is different! The modern design allows for multiple communication configurations including NMEA 2000. Signal Filters™ is Designed to pass UL 1105 ABYC and US Coast Guard fuel system requirements.

Why do I need to communicate with my fuel filter?

Consider its location and its function, out of site and out of mind. What if your fuel filter could send you a notification that it needed service? Notification BEFORE harm to your engine may occur or ruin a day on the water. Signal Filters™ can do this.



SIGNAL FILTERS™ FILTER TESTING

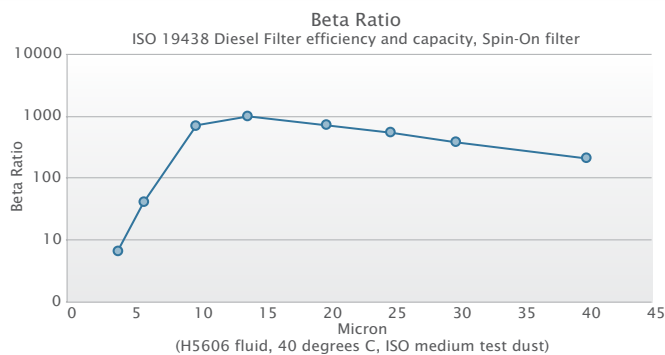
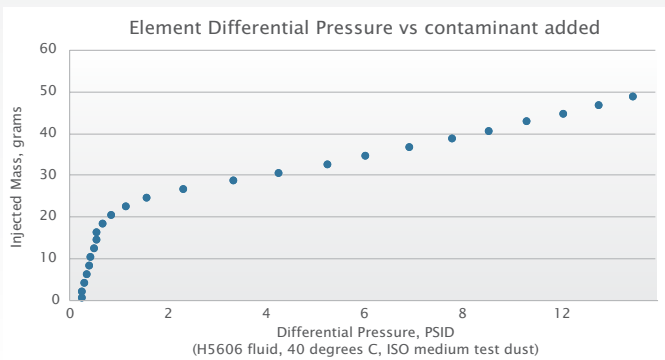

PART NAME:	SFF-010-04, SFF-010-06, SFF-010-08
TEST METHOD:	Fuel water separation per SAE J1488
FUEL FLOW RATE:	240L/h

SIGNAL FILTERS™ FILTER UNDISSOLVED WATER, PPMV				
Time (min)	DP kPa	Influent	Effluent	Efficiency (%)
0	4.5	<5	<5	<99
10	4.5	2392	<5	<99
30	4.5		<5	<99
50	4.5	2212	<5	<99
70	4.7		<5	<99
90	4.7	2363	<5	<99
110	4.7		<5	<99
130	4.7	2230	<5	<99
150	4.7	2375	<5	<99
Average Efficiency				<99

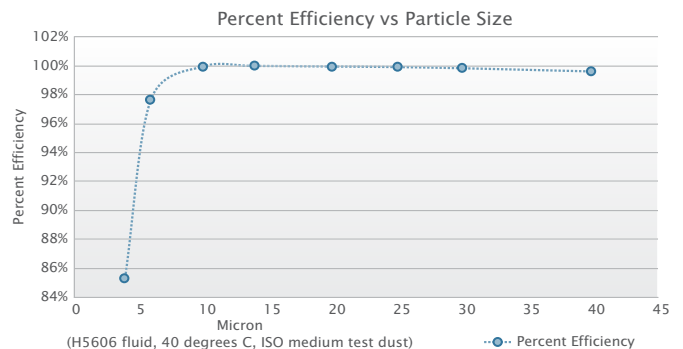

SPECIFICATIONS:

WIRE CONNECTIONS

- Signal Filters™ connects to supplied wire harness pigtails or to the customer's own wire harness.

FILTER HEAD

- Cast 316 stainless steel head/mounting bracket with (4) 3/8 inch NPT ports.

DISPOSABLE SPIN ON FILTER

- Standard can diameter (3-3/4") available in three lengths: 4", 6", 8"

FILTER MEDIA SPECS

- 10 micron custom formulated paper filter media removes 99% of free water.

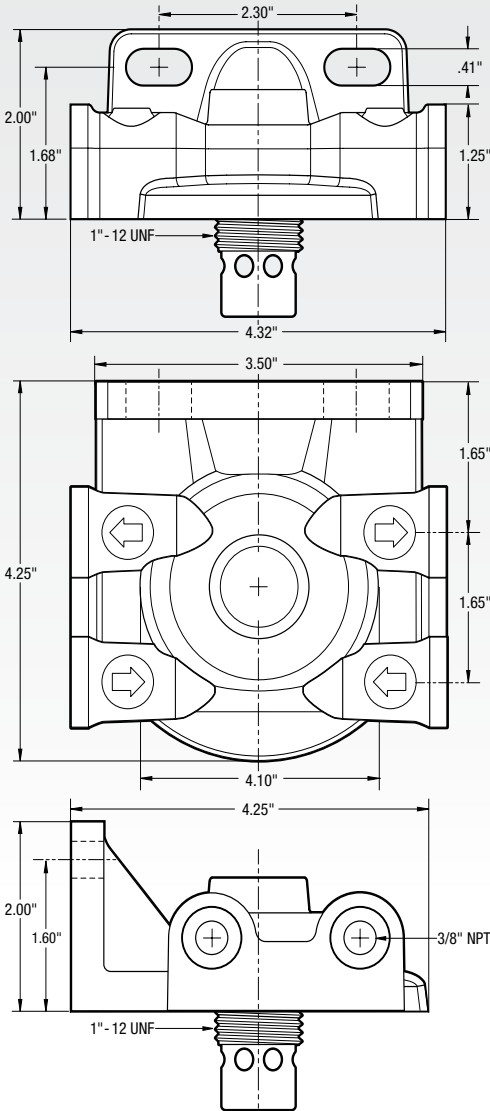

Filter Head Mount compatible with most industry standard heads

SIGNAL FILTERS™ FILTER HEAD ASSEMBLY KITS

For use with the Signal Filters™ water separating fuel filter



HEAD #SFH-N2K-SS Includes:

- 316 Stainless Steel Head with 3/8" NPT ports and 1" -12 UNF threaded spud
- Plugs into the NMEA 2000 network
- Shows alerts on your multi-function display



KIT #SFH-SS-G1 Includes:

- 316 Stainless Steel Head with 3/8" NPT ports and 1" -12 UNF spud threaded spud
- Gauge with indicator
- Wire harness and connectors



KIT #SFH-SS-G2 Includes:

- Two - 316 Stainless Steel Heads with 3/8" NPT ports & 1" -12 UNF threaded spud
- Gauge with Port and Starboard indicator
- Wire harness and connectors



KIT #SFH-SS-L3 Includes:

- 316 Stainless Steel Head with 3/8" NPT ports and 1" -12 UNF threaded spud
- Imbedded indicator light driver circuit interface with indicator light
- Wire harness and connectors

SIGNAL FILTERS™ FUEL FILTERS

The Signal Filters™ water separating fuel filter is a 10 micron high efficiency spin on filter available in three different lengths



#SFFF-010-04 Filter

- 4 INCH spin on Fuel Filter
- 10 micron high efficiency



#SFFF-010-06 Filter

- 6 INCH spin on Fuel Filter
- 10 micron high efficiency



#SFFF-010-08 Filter

- 8 INCH spin on Fuel Filter (Includes 1/8-27 pipe plug)
- 10 micron high efficiency
- UL listed marine drain available at extra cost

Go to website for more info: SignalFilters.com

Signal Filters™ is a registered trademark of and manufactured by Entratech Systems LLC | SignalFilters.com



Patented "Probe in Can"™ Technology.

202 East Fox Road
Sandusky, Ohio 44870

419.433.7683
sales@SignalFilters.com

